



DIAMOND

HEX[™] PRO

**6.5" COMPONENT SYSTEM
INSTALLATION MANUAL**

HP650

SPECIAL THANKS

Dear Valued Customer,

All of us at Diamond Audio would like to thank you for your purchase of a HEX™ Pro speaker system. HEX™ Pro component systems and subwoofers are the very best speakers available for use in the automobile environment. By choosing these products you recognize the value in using only the best. With our proprietary HEX™ cones and neo motors that utilize our patented TDX™ technology, we know you will be satisfied with these systems for years to come.

Please keep in mind that prolonged exposure to sound pressure levels in excess of 100 dB can cause permanent hearing loss. This high performance speaker system can exceed that level, so please exercise restraint in its operation in order to preserve your ability to enjoy its fidelity in the future.

Because of their flexible installation possibilities, please consider having your new speakers professionally installed by an authorized Diamond Audio dealer. This will assure a clean and efficient installation, and extend your one year warranty to three years.

At Diamond Audio, we strive to bring honest value and excellent quality to all of the products we build. By your purchase of this product, you have joined the growing family of discerning listeners who demand only the best. Welcome!

The Diamond Audio Team

Thermal-Dyne eXtreme™ is a fundamentally different solution. The concept is simple, eliminate the detrimental effects of heat in a loudspeaker system. The solution however, is quite complex. Our engineers decided to start with a fresh sheet of paper and build a new line of products that addressed the thermal problems and shortcomings of conventional designs while significantly raising the existing level of performance.

To understand TDX™ speaker technology, it must first be compared to that of a conventional speaker design. At the heart of every speaker is a permanent magnet motor structure that provides the magnetic energy, or force to move the voice coil back and forth within the magnetic air gap. Conventional speakers use a large ceramic magnet surrounding the voice coil that actually retains heat rather than dissipating it. TDX™ motors use a small but very efficient high temperature Neodymium magnet mounted inside the voice coil. The geometry, venting and material selection for the motors have all been optimized for ideal thermal dissipation. The TDX™ thermal efficiency is nearly (5) times greater than conventional designs. In conjunction with the motor design, TDX™ Technology utilizes die-cast aluminum frame structures to act as a heat sink for the encapsulated motor structure. To insure maximum heat transfer from the encapsulated motor case to the aluminum frame, a special thermal paste fills any surface voids that may be present in this mating surface.

The evolution of TDX™ Technology can be seen in the new HEX™ Pro series of products. The new HEX™ Pro component systems take this TDX™ Technology and expand on it to maximize the benefit for superior full spectrum audio performance. To faithfully reproduce an extended frequency range, the materials and design must be optimal. This coupled with a demand for very high power handling, is extremely challenging. These systems utilize an improved version of our legendary HEX™ cone, our patented dual-tuned chamber tweeter along with our extruded aluminum, high power, programmable crossover to make the very best speaker system available in mobile audio. Period.

FEATURES

- TDX Technology™ (Thermal Dyne eXtreme)™
- Proprietary Kevlar™/Nomex™ Hex™ Cone
- Butyl Rubber Surround
- Flat Blended Nomex™ Spider with Embedded Lead Wires
- Die-cast Aluminum Frame
- Ultra-high Energy Neodymium Magnet Structure
- 30mm Polymer Treated Alloy Domed Tweeter
- Precision Model Matched Programmable Crossovers

Parts List - HP650

- (2) HEX™ Pro Mid-Bass Speakers
- (2) Mounting Gaskets
- (2) HEX™ Pro Crossovers
- (2) HEX™ Pro Tweeters
- (1) Mid-Bass Mounting Hardware Kit
- (1) Tweeter Mounting Hardware Kit

HEX™ PRO MID-BASS DRIVER ASSEMBLY

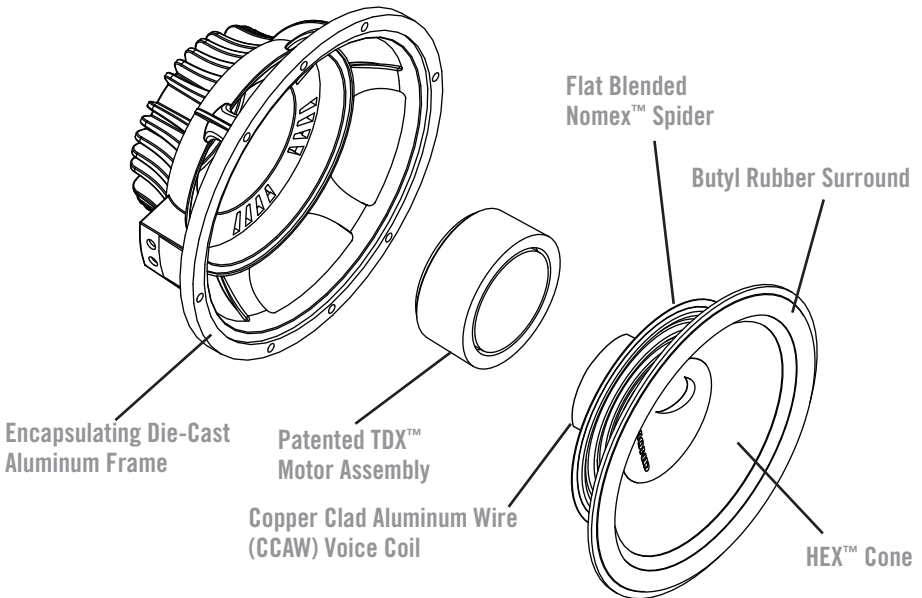

MOUNTING

Mid-Bass Mounting

The illustration above shows the parts included and correct mounting assembly of the HEX™ Pro component mid-bass drivers. Be sure to check the available mounting depth before installation begins. Use of the foam gasket is recommended to ensure a proper seal between the speaker and mounting surface.

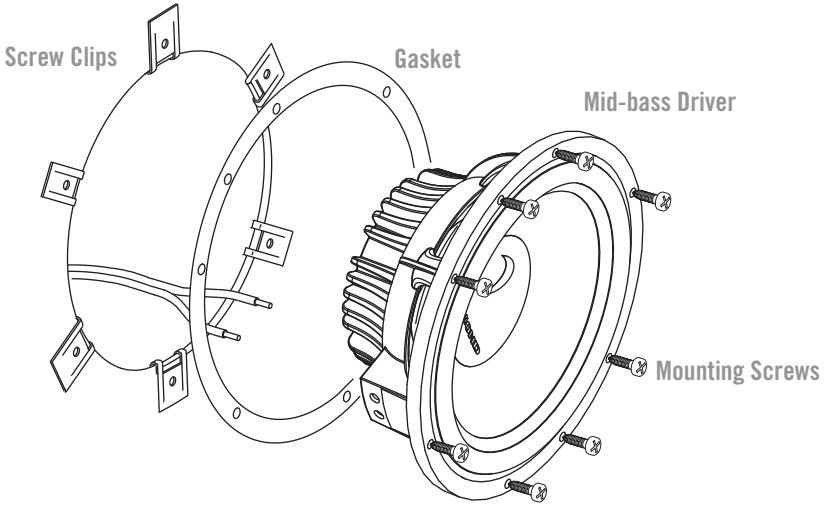

Tweeter Mounting

When mounting the tweeters, make sure desired location can accommodate the hole size, over all diameter and depth required. Cut a hole in the surface chosen and feed speaker wire through. Remove the tweeter mounting ring by unscrewing it counter clockwise. Connect speaker wire to tweeter terminals and mount tweeter in hole using provided screws. When tweeter is secure, replace trim ring by screwing it on clockwise.

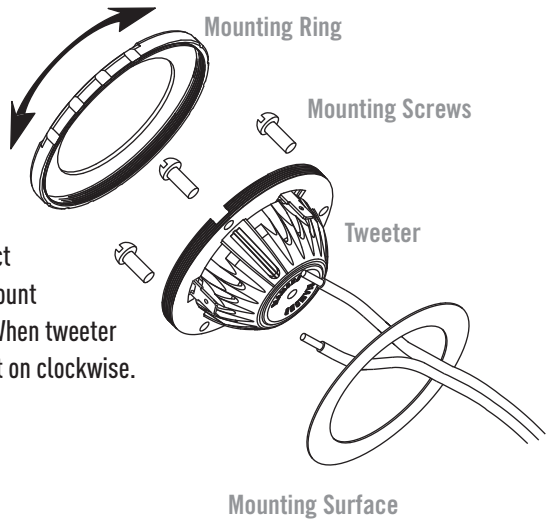

CROSSOVERS

Each HEX™ Pro component system comes with a pair of programmable crossovers. These crossovers use a combination of 12 and 24 dB/oct slopes to optimize the output of the tweeter and mid-bass driver. Each crossover features complete tweeter level, phase, and bi-amp programming capability. An LED found on top of the crossover is used as a power limit indicator. When brightly lit, it indicates that maximum power is being delivered to that channel.

Crossover Programming

Under the sliding cover on the crossover is where the programming controls are located. The tweeter level control has four settings: +2, 0, -2, -4 dB. This is adjusted by changing the combinations of the two toggle switches labeled “TWT LEVEL”. Use the key to the right of the switches to configure tweeter level control. Switch the “BI-AMP” switch only when running the crossover with a bi-amped signal. The “PHASE” switch swaps the tweeter 180 degrees out of phase for off axis tweeter installations.

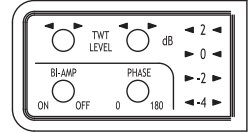

COMPONENT SYSTEM CONNECTION

The following illustration shows how to connect one channel of the HP650 component system.

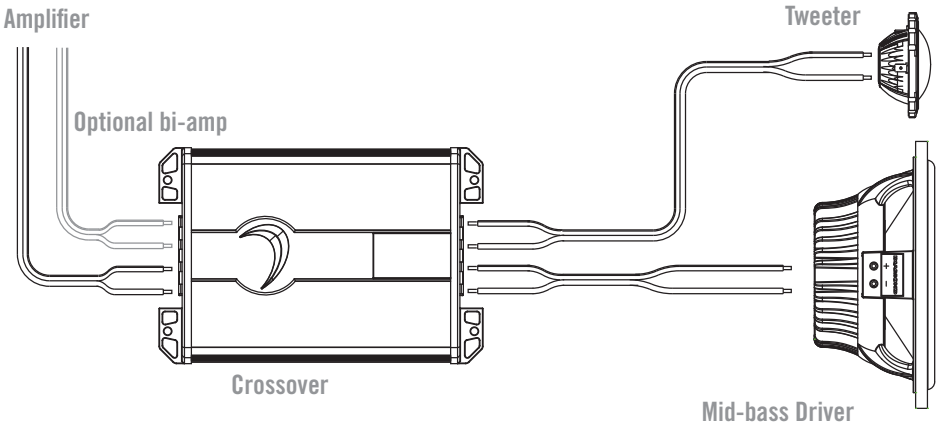

THIELE/SMALL PARAMETERS

Parameter (unit)	HP650M	HP650T
Sensitivity - 2.83V@1M (dB)	90	93
Qts	0.62	N/A
Fs (Hz)	60	850
Vas (L)	10.0	N/A
Re (ohm)	3.30	7
Xmax (mm/N)	4	N/A
Impedance (ohm)	4	8
Power (Watts) Nom/Max	150/300	75/150

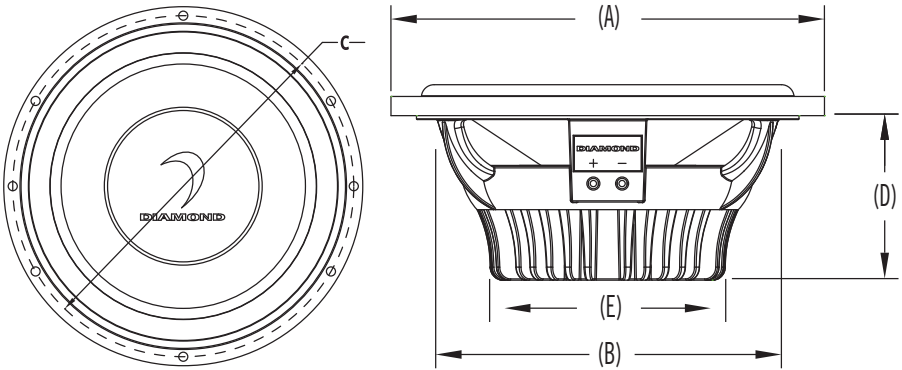

PHYSICAL DIMENSIONS

Dimension (Inches)	D652	D662	S.0ta/s
Total Diameter (A)	5.57" (141.6mm)	6.50" (165.4mm)	2.3" (58.42mm)
Mounting Diameter (B)	4.60" (117.3mm)	5.50" (140.6mm)	1.875" (47.63mm)
Screw Hole Diameter (C)	5.23" (133mm)	6.14" (156mm)	N/A
Mounting Depth (D)	2.16" (55mm)	2.32" (59mm)	0.8" (20.32mm)
Magnet Diameter (E)	3.07" (78mm)	3.40" (86.4mm)	N/A

LIMITED SPEAKER WARRANTY STATEMENT

Diamond Audio Technologies, LLC (DAT) warrants this product to be free from defects in material and workmanship for a period of one (1) year from the original date of purchase provided it was purchased from an authorized DAT retailer within the United States. However, if this product was installed by the authorized DAT retailer, the warranty period will be extended to three (3) years.

THIS WARRANTY IS NOT TRANSFERABLE AND APPLIES ONLY TO THE ORIGINAL PURCHASER OF THIS PRODUCT IN ITS ORIGINAL INSTALLATION. Original purchaser must reside in the United States and be able to provide proof of purchase and installation with the sales receipt from the authorized DAT retailer that sold and installed the product.

Should a manufacturing defect occur during above said warranty period, DAT will replace or repair the defective product with a product of the same or equivalent value and performance.

Damage or failure caused by any of the following is not covered under this warranty policy: negligence, improper use, abuse, product modification, unauthorized repair attempts, accident, acts of God, misrepresentations by DAT retailers, and improper/inadequate packaging during return shipping.

Warranty is void if serial numbers have been removed, altered or defaced.

HOW TO OBTAIN WARRANTY SERVICE

In the event a DAT product should require service, you should visit the authorized DAT retailer you purchased the product from and they can expedite your claim. All claims must fall into the guidelines listed above and be accompanied by a copy of the original sales and installation receipt from that authorized DAT retailer.

Product returned for warranty service must be freight-prepaid, properly packaged and clearly marked with the Return Authorization (RA) number issued by DAT. Any product returned to DAT that is improperly packaged, does not have a RA number clearly marked on the package, or never received a RA number may be refused upon delivery. DAT does not assume responsibility for lost or misdirected product.

Repair or replacement under this warranty is the exclusive remedy of the consumer. DAT shall not be liable for any incidental or consequential damages for breach of any expressed or implied warranty on this product. Some states do not allow the exclusion or limitation of incidental or consequential damages, or allow limitations on how long an implied warranty lasts, so the above limitations or exclusions may not apply to you. This warranty gives you specific legal rights and you may also have other rights that may vary from state to state.

Customers outside the United States should contact their local sales office to obtain information on pricing, exchange unit availability, instructions, service and warranty/non-warranty replacement or repair.



DIAMOND
AUDIO TECHNOLOGIES, LLC

Diamond Audio Technologies, LLC

6915 West Frye Road
Chandler, AZ 85226 USA
Tel: 480.820.2075
Fax: 480.813.6210
Web: diamondaudio.com

Service/Tech Support:

480.820.2075

Tech Support Email

techsupport@diamondaudio.com